

A-A

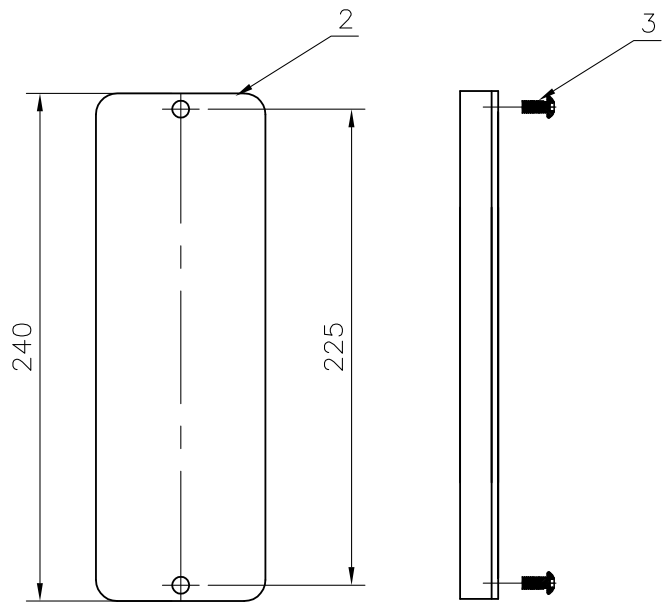

DOOR

- NOTES:**
1. POLES DESIGNED IN ACCORDANCE WITH BCA, AS 4100:1998, AS/NZS 1170.2:2002, AS 1798:1992, AS/NZS 4676:2000, AS/NZS 4677:2000.
 2. HOT ROLLED STEEL FLAT PRODUCTS CONFORM TO AS 1594.
 3. HOT ROLLED STEEL BARS AND SECTIONS CONFORM TO AS 3679.
 4. WELDING OF STEEL STRUCTURES CONFORM TO AS/NZS 1554.1:2004.
 5. ALL STEEL ITEMS FULLY HOT DIP GALVANISED AFTER FABRICATION TO AS/NZS 4680:2006.
 6. HOT ROLLED STEEL PLATES CONFORM TO AS 3678.
 7. ALL DIMENSIONS ARE IN MILLIMETRES.
 8. ALL INFORMATION SUBJECT TO CHANGE WITHOUT NOTICE.



Advanced
LIGHTING TECHNOLOGIES

PRODUCT CODE:
ADWPPR04.0600D233***

**Denotes Colour / Finish*

4.0M POLE PIPE ROUND WITH 60MM OD SPIGOT

POLE WEIGHT: 40KG
REVISION DATE: 23 09 2024

ADVANCED LIGHTING TECHNOLOGIES
110 LEWIS ROAD WANTIRNA SOUTH VIC 3152
03 9800 5600 | ADLT.COM.AU