



CREE XSP SERIES: THE DIFFERENCE YOU CAN SEE. THE PAYBACK YOU EXPECT.

Better LPW, Same Great Performance

Efficiency gains of up to 25% over existing XSP Series fixtures mean greater energy savings—and even faster payback.

Better Function, with the Same Form

High Output comes to our popular cobra-head luminaires for increased street, roadway and area applications. A wider range of lumens, more LPW, and a full range of optics and CCT add up to a quicker route to replacing high pressure sodium and metal halide technologies—from 70W to 250W.

Easy Does It!

Easy design, installation and operation make the XSP Series the right choice for many applications. It features excellent backlight, uplight and glare control and a state-of-the-art DeltaGuard® finish—backed by our 10-year limited warranty.

Cree® XSP Series

XSP LED Street/Area Luminaire

BRIGHTER PATH TO SAVINGS.

The Cree® XSP Series LED street and area luminaires deliver up to 17,000 lumens with incredible efficiency and illumination performance you need. In addition to substantial energy and maintenance savings, the XSP Series achieves better optical control with the NanoOptic® Precision Delivery Grid™ optic over incumbent street lighting solutions from 70W up to 250W.

PERFORMANCE SUMMARY

NanoOptic® Precision Delivery Grid™ optic

Initial Delivered Lumens: 5,422 - 17,230

Input Power: 41 - 138W

Efficacy: up to 140 lm/W

CRI: Minimum 70 CRI

CCT: 3000K (+/- 300K); 4000K (+/- 300K); 5700K (+/- 500K)

Input Voltage: 220-240V (50/60 Hz)

Limited Warranty:

Class 1 - 10 years on luminaire/ 10 years on Colorfast DeltaGuard® finish
 Class 2 - 5 years on luminaire/10 years on Colorfast DeltaGuard® finish*
 Extended warranty (up to 10 years) available for Class II luminaires on approved projects.
 Contact ADLTA for further information.

* Product specifications subject to change at any time.
 Visit cree-europe.com to find the most up-to-date information.

CREE LED LIGHTING TECHNOLOGY



NanoOptic® Technology

With patented NanoOptic® Technology available in multiple distributions, Cree® outdoor LED fixtures provide precise optical control for exceptional application performance and energy savings. The NanoOptic® refractor system offers superior light control with more lumens delivered in the target area, improved uniformity ratios and controlled high-angle brightness.



Colorfast DeltaGuard® Finish

Cree's exclusive Colorfast DeltaGuard® Finish protects our LED outdoor fixtures without compromise. Immersive conditioning across 18 stages delivers an e-coat epoxy primer with an ultra-durable powder topcoat, providing unmatched protection against corrosion, UV light, fading and weathering complete with a 10-year limited warranty.

XSP1™

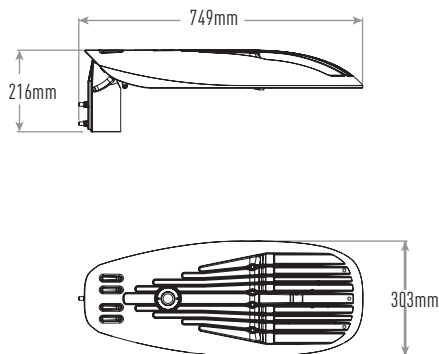

XSP2™

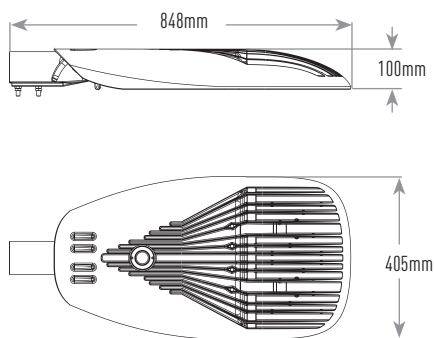

APPLICATIONS



Street & Roadway Lighting

Cree® LED luminaires contribute to a healthy bottom line by reducing energy consumption, maintenance costs and the carbon footprint while keeping pedestrians and vehicles visible and safe at night.

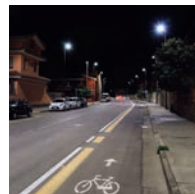

Municipal & Residential Lighting

Upgrade municipal lighting in streets, public buildings, walkways, parking structures, and common areas. Not only will this help keep your operating and maintenance budget in check, it will provide dramatically better visibility — making public areas safe and secure.



Car Park Lighting

Installing Cree® LED lighting in your car park enhances your brand and reduces total cost of ownership and the carbon footprint, while providing a more inviting shopping experience for customers.

© 2016 Cree, Inc. All rights reserved. For informational purposes only. Not a warranty or specification.
 See lighting.cree.com/warranty for warranty and specifications. Cree®, NanoOptic®, and Colorfast DeltaGuard® are registered trademarks, and the Cree logo, Precision Delivery Grid™, XSP1™, XSP2™ and XSPR™ are trademarks of Cree, Inc.
 Rev. Date: 05/16/16

Advanced Lighting Technologies Australia Inc
 Advanced Lighting Technologies New Zealand Ltd
 Advanced Lighting Technologies Asia Pte Ltd

Australia
 New Zealand
 Singapore

+61 3 9800 5600
 +64 09 415 6332
 +65 6844 2338

www.adlt.com.au
www.adlt.co.nz
www.adlt.com.sg